

## Measuring Prism in Progressive Addition Spectacle Lenses

Edward Kuwera, MD<sup>1\*</sup>, Alexander Christoff, CO<sup>2</sup>, Ornit Crystal, MD<sup>3</sup>, Josephine Ibrionke, OD<sup>4</sup>  
David L. Guyton, MD<sup>5</sup>

\*The Zanvyl Krieger Children's Eye Center, The Wilmer Eye Institute, The Johns Hopkins University School of Medicine, Baltimore, Maryland.

*\*Corresponding Authors: Edward Kuwera, MD, The Zanvyl Krieger Children's Eye Center, The Wilmer Eye Institute, The Johns Hopkins University School of Medicine, Baltimore, Maryland.*

### Abstract

**Background:** Patients frequently go to eye care providers without knowing the prescription of their glasses. Progressive addition lenses can already be difficult to measure, especially when the prescription is unknown and lens markings are not visible. With the addition of ground-in prism, this problem is further compounded, and there is no standard methodology to minimize user error.

**Purpose:** This paper emphasizes the problems inherent in measuring such spectacle lenses, and describes a technique that best approximates prism power in this situation.

**Methods:** The distance viewing point of the lens is first marked, and effective vertical and horizontal prism powers are measured separately. Finally, the add power is estimated by measuring the increase in power, in the plus direction, from the top of the lens to the lowest portion of the progressive corridor. Staying within the progressive corridor is aided by avoiding the appearance of induced astigmatism when straying toward the edge of the corridor.

**Conclusions:** This manuscript provides a standardized and repeatable method for measuring progressive add spectacles with prism.

**Keywords:** Progressive addition lenses, prism in progressive addition lenses, progressives, prism, PAL, PALs, prism reference point, measuring prism, measuring spectacle prism.

### INTRODUCTION

Measuring progressive addition lenses (PALs) can be difficult and inaccurate, especially when the intended prescription is unknown. Problems arise from prism effects, varying astigmatism, and indistinct location of the distance and near zones (especially when the lens guide markings, both painted and laser-etched, have faded over time). Occasionally the progressive power zone has been partially cut off when fitting the lens into a small spectacle frame. The presence of prism in the lens further complicates the measurement process.

The optical center (OC) of a lens is the point at which the chief light ray traverses the lens without deviation,

in other words where no prismatic effect is present. Without prism, the OC becomes the major reference point (MRP) of the lens, and is meant to be centered on the patient's pupil. In prismatic lenses, the MRP and OC are separated.<sup>1,2</sup> The location of this point is difficult to identify because the MRP is adjusted in each eye, individually, to account for induced prism and eye position in the presence of prism, so one cannot simply measure an equivalent location on both lenses and expect accurate results.<sup>3</sup>

Here we describe a repeatable and accurate method for using a manual lensmeter to measure the effective prism in PALs, along with the progressive add power, when there are no identifiable markings on the spectacle lens. There are many publications on how

## Measuring Prism in Progressive Addition Spectacle Lenses

to dispense progressive addition lenses,<sup>1,3,4</sup> and how to measure the amount of slab-off prism or reverse-slab prism in spectacle lenses,<sup>5</sup> but to the best of our knowledge, no standardized technique has been described for measuring PALs with prism. Care must be taken when changing the amount of prism in a spectacle lens to a different value because the amount of prism already in the spectacle lens may be measured entirely differently by the clinician and the optician.

### METHODS

We use a manual lensmeter with a prism compensator as shown in Figure 1A. Some familiarity with this device is assumed in this paper.

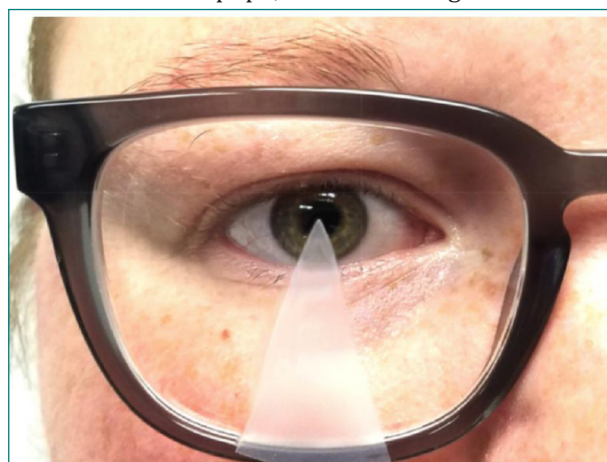

**Figure 1A.** Manual lensmeter

### Reference Points

The key to measuring prism is to find the “prism reference point.” This is related to the position of the “distance reference point”. The distance reference point is the point that is meant to be centered on the pupil when the patient is looking straight ahead into the distance. The prism reference point is sometimes described as usually being 2-4 mm below the fitting cross in progressive add lenses, probably as a compromise between distance and near viewing.<sup>6</sup> This compromise is not standardized, however, and for our purpose we shall use the distance reference point as the location of the prism reference point, for two reasons. First, the distance reference point is the point where the actual power of the prescribed prism has its exact effect for distance viewing. Secondly, we are concerned about inappropriately measuring prism at any lower point than at the distance reference point in progressive power lenses because of too easily getting into the additional prism effects of the progressive power portion of the spectacle lens.

In order to determine the distance reference point of each lens that the patient is wearing, the examiner should sit directly in front of the patient, close one eye, and sight the eye of the patient ipsilateral to your open eye, with each of your eyes in turn, while asking the patient to always look with both eyes at your open, sighting eye. You then mark the center of the patient’s pupil in the eye ipsilateral to your sighting eye to locate the distance reference point for each eye. A pen with washable ink may be used, a Wite Out® pen (BIC Corporation, Shelton, CT), or preferably we apply a triangular piece of frosted plastic tape, such as Scotch® Magic® tape, such that the tip of the tape marks the exact center of the pupil, as shown in Figure 2C.



**Figure 2C.** Placing a piece of plastic tape with its tip in the centre of the pupil, while the patient looks at the ipsilateral sighting eye of the examiner

### Placement into the lensmeter

Place the spectacles into the lensmeter with the mark on the lens or tip of the tape centered in the nosecone of the lensmeter. Focus the lensmeter target. For the measurement of prism, if not immediately obvious from the reticle in the lensmeter eyepiece, it is helpful to rotate the crossed-line-type lensmeter target so that the lines are vertical and horizontal, if they will still stay in reasonable focus.

### Measuring vertical prism

To measure the vertical prism in each lens, the vertical displacement of the horizontal luminous lines from the center of the lensmeter reticle may be read directly, with upward displacement indicating base-up prism, and downward displacement indicating base-down prism. In other words, the lines are displaced in the direction of the prism base. Alternatively, the

## Measuring Prism in Progressive Addition Spectacle Lenses

prism compensator may be rotated to give vertical prism effect, and its dial turned until the horizontal luminous sphere lines are centered in the reticle. In our manual lensmeter, base-up prism is indicated on the prism compensator dial by white numbers with a positive value, and base-down by red numbers with a negative value. Record the direction and amount of prism in prism diopters (PD) for each lens. The difference between the two measurements yields the total amount of vertical prism, measured between the distance reference points. See Figure 3.

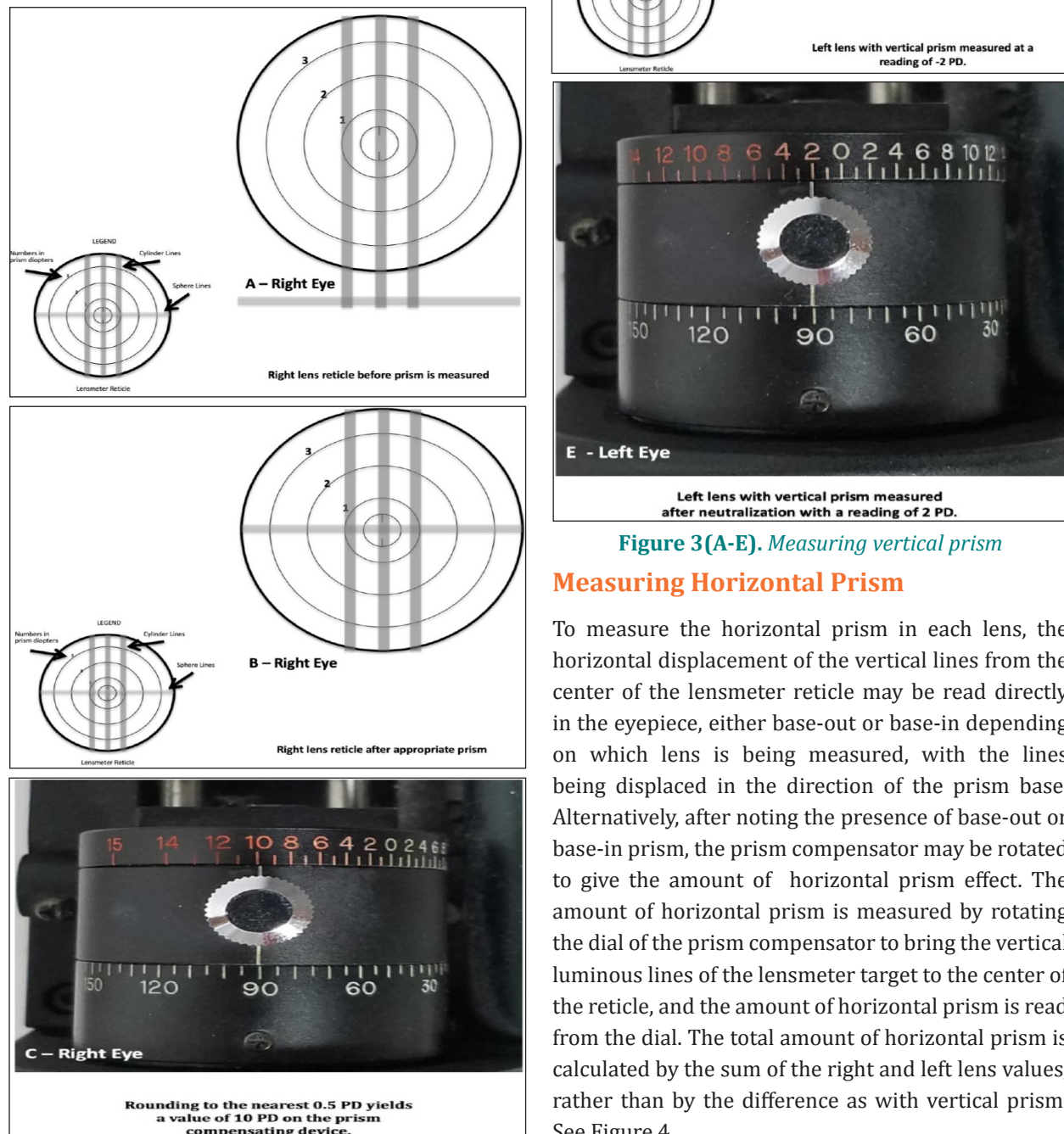

Figure 3(A-E). Measuring vertical prism

## Measuring Horizontal Prism

To measure the horizontal prism in each lens, the horizontal displacement of the vertical lines from the center of the lensmeter reticle may be read directly in the eyepiece, either base-out or base-in depending on which lens is being measured, with the lines being displaced in the direction of the prism base. Alternatively, after noting the presence of base-out or base-in prism, the prism compensator may be rotated to give the amount of horizontal prism effect. The amount of horizontal prism is measured by rotating the dial of the prism compensator to bring the vertical luminous lines of the lensmeter target to the center of the reticle, and the amount of horizontal prism is read from the dial. The total amount of horizontal prism is calculated by the sum of the right and left lens values, rather than by the difference as with vertical prism. See Figure 4.



## Measuring Prism Lines in Progressive Addition Spectacle Lenses

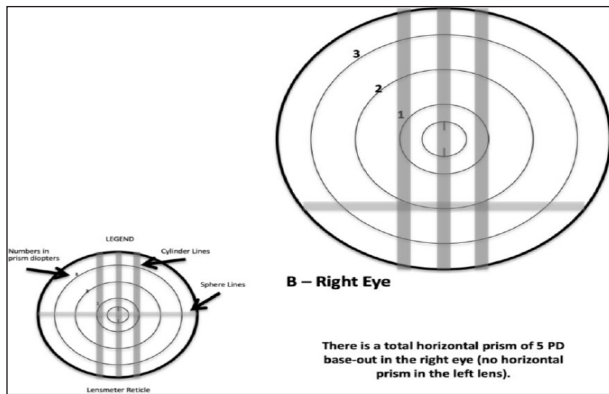
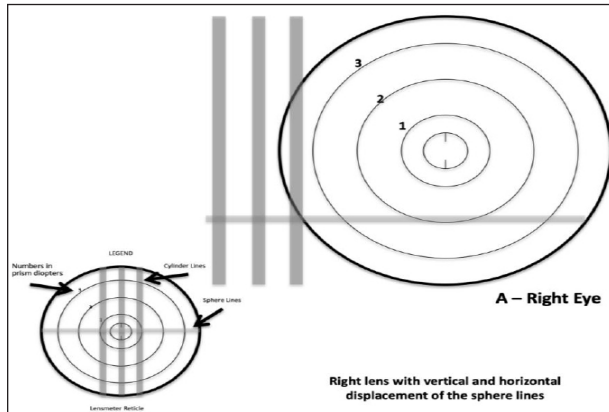

With the prism compensating device set to measure horizontal prism, there is a total of 5 PD base-out in the right eye (no horizontal prism in the left lens).

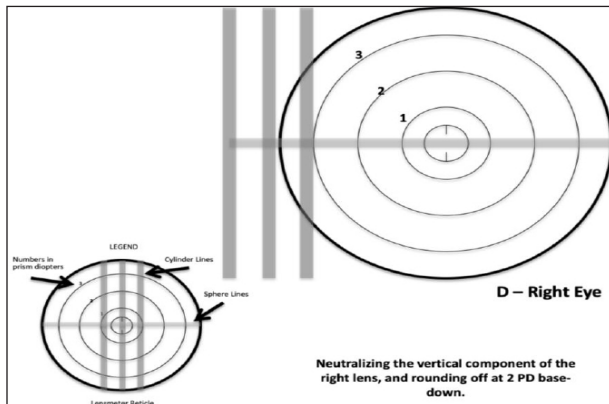

Neutralizing the vertical component of the right lens, and rounding off at 2 PD base-down.

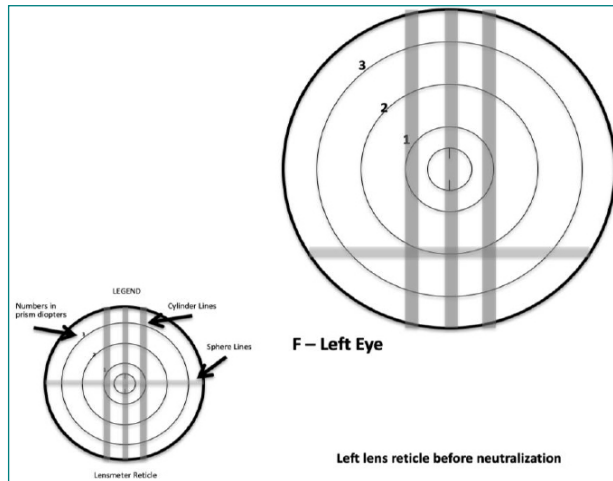

Left lens reticle after neutralization with vertical prism measured at 2 PD base-down

**Figure 4(A-G).** Measuring horizontal and vertical prism together

## Measuring Prism in Progressive Addition Spectacle Lenses

If there is no prism compensation device on the lensmeter and either the horizontal or vertical luminous lines are displaced out of view of the target reticle, hold an estimated appropriate amount of prism with the base directed in the opposite direction of the displaced luminous lines. This should bring the lines into view, whereby the residual amount of prism can be read from the reticle.

## Measuring Reading Add Power

The best way to measure the add power of a progressive addition lens begins with first neutralizing the distance portion of the lens as high up on the lens as possible, using the prism compensator to center the luminous lines in the reticle as best possible for best focused clarity. The temples of the glasses should be turned toward the examiner, with the front surface of the lens against the nosecone of the lensmeter because add power is fabricated and measured as front vertex power. Once the axis of the astigmatism has been found, no longer turn the axis dial, but focus the more vertical of the lines of the crossed-line target and note the dioptric reading. Then move the lens up so that the bottom-most portion of the lens is against the nosecone, again using the prism compensator to center the target lines in the reticle as best possible for best focused clarity. Here, find the center of the progressive corridor by moving the lens side-to-side, while focusing with the power wheel, until the more vertical lines of the lensmeter crossed-line target are still unbroken and in best focus, as they were when measuring through the top portion of the lens. Note the dioptric reading and subtract the reading through the top of the lens from the reading at the bottom of the lens to obtain the full add power.

It is of utmost importance to find the center of the progressive corridor when measuring through the bottom of the lens because of astigmatism and distortion present outside of the corridor. The technique just described uses the detection and avoidance of this astigmatism by the side-to-side movement of the lens to find the center of the progressive power corridor. If the add portion is measured outside of the progressive corridor, there can be significant error introduced.

The fabricated progressive addition power can usually be determined by locating the add reference number faintly laser-etched into the temporal aspect of the front surface of the progressive addition lens. This is best seen in glancing reflected light. See Figure 1B and 1C.

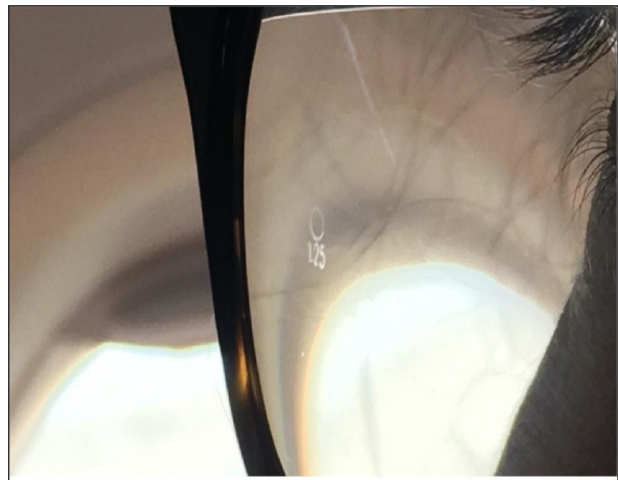
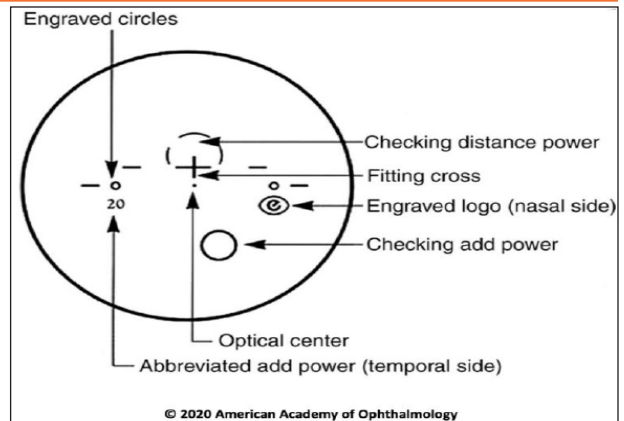

**Figure 1 (B-C).** *Glancing Reflected Light*

The fewest characters possible to uniquely designate the add power are used. For example, “12” indicates an add of +1.25 D, and 27 indicates an add of +2.75 D. If this value is greater than your measured value, consider that the bottom-most portion of the lens may have been cut away for the lens to fit within a too-small frame. See Figure 5 A-C.

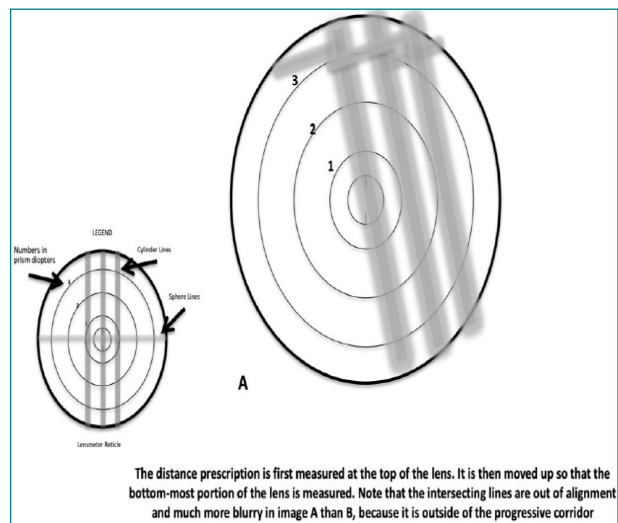

## Measuring Prism in Progressive Addition Spectacle Lenses

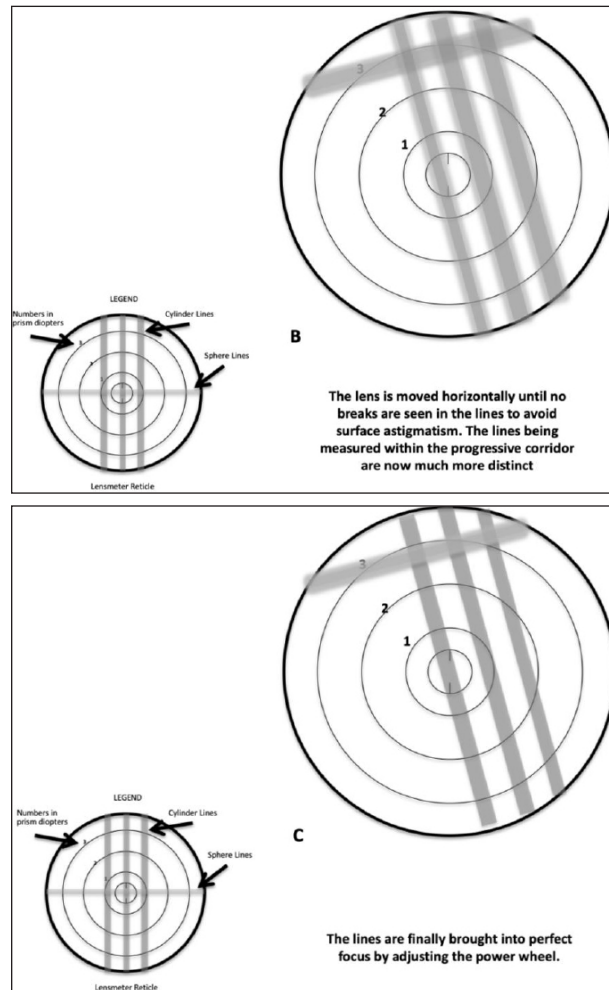

Figure 5(A-C). *Measuring the progressive add*

### DISCUSSION

Note that any spectacle lens that has dioptric power has innate prism power away from the optical center of the lens according to Prentice's Rule. This induced prism power varies in direction and magnitude from point to point on the lens. It is easy enough to measure the dioptric power of the lens at the optical center of the lens when there is no added prism. But when prism has purposefully been added, the optical center is displaced away from the patient's pupil, and the displaced optical center can no longer be used as the reference point to measure the amount of the effective power of the lens or effective power of the prism. The position of the patient's pupil becomes the best reference point to use. So unless the patient is present to allow marking of the pupil centers, the proper reference point for measuring prism power cannot be known. If the interpupillary distance has been measured, and the patient's nose is in the midline,

then the amount of horizontal prism in each lens can be measured with good accuracy. But without knowing the vertical position of the pupils, the vertical prism cannot be measured accurately unless the powers of the vertical meridians of both spectacle lenses are exactly the same, which is unusual.

### Common Measurement Methods in Practice

To document the lack of a unified technique for measuring vertical prism in spectacle lenses, co-author Ornit Crystal conducted a survey in Maryland in which 770 optometrists and opticians were mailed a questionnaire asking them to indicate their method of determining the power of vertical prism in spectacle lenses. Four options were offered, and additional space was left for comments or other methods employed. The following four options were provided:

1. Mark the spectacle lens directly in the center of the patient's pupil and measure the prism at this point.
2. Measure at the geometrical center of the frame.
3. Determine the optical center of the stronger lens and measure at this same level in the weaker lens, thus measuring the total vertical prism as if it is in the weaker lens.
4. In the case of bifocals, measure at a specific distance above the top of the lower segment.

She received 253 replies with the following results: Options 1, 2, 3, and 4 were favored by 25.2%, 10.6%, 51.7%, and 3.5% of the respondents, respectively. Two percent simply referred to the American National Standard Z80.1 20051<sup>7</sup> (which actually does not address the measurement of vertical prism when the intended prism is not known). Six percent gave contradictory answers. These results confirmed the lack of consensus in the community. This problem is further complicated when working with progressive addition spectacles for the reasons described earlier.

Dr. Crystal's report of her study was rejected by three ophthalmic journals, with editors' comments that it belonged in an opticianry journal or surely was addressing an insignificant problem. We heartily disagree, especially in one particular situation that we encounter frequently - in patients having glasses correcting significant anisometropia. If these glasses already have vertical prism, and the clinician wishes to add more vertical prism, it is hazardous to specify the actual prescription because the examiner and the

## Measuring Prism in Progressive Addition Spectacle Lenses

optician may be measuring the existing vertical prism in an entirely different manner. In this situation, the only semi-accurate way to prescribe the new glasses is to ask the optician to add the desired amount of new prism to whatever he or she measures in the old glasses, and not to specify the exact amount of vertical prism desired in each lens!

### CONCLUSION

We believe that this paper provides a repeatable and accurate method of measuring progressive addition spectacle lenses with prism, especially vertical prism, when there are no identifiable markings, and hope that these techniques will one day come to be the standard for all who work with PALs and prism.

### REFERENCES

1. Garber N. Advanced Manual Lensometry: A Self-Learning Guide for Evaluating Multifocal and Specialty Lenses, Progressive Lenses, Prisms, and Rigid Contact Lenses. *Journal of Ophthalmic Nursing & Technology*. 2000;19(4):184-191.
2. Brooks CW, Borish IM. *System of Ophthalmic Dispensing, 3rd ed*. Vol 17. Boston: Butterworth-Heinemann; 2007.
3. Brooks C, Riley H. Effect of prescribed prism on monocular interpupillary distances and fitting heights for progressive add lenses. *Optometry and Vision Science*. 1994;71(6):401-7.
4. Kozol F, Capone R, Kozol N. Determining the vertical and horizontal positioning of multifocal and progressive lenses. *Survey of Ophthalmology*. Jul-Aug 1998;43(1):71-82.
5. Christoff A, Guyton DL. How to measure slab-off and reverse slab prism in spectacle lenses. *JAAPOS*. 2006;11(4):414-415.
6. Brooks CW. *Essentials of Ophthalmic Lens Finishing Second Edition*. St. Louis: Butterworth-Heinemann; 2003.
7. American National Standard Z80.1-2005. *American National Standard for Ophthalmics-Prescription Ophthalmic Lenses - Recommendations*. Merrifield: American National Standards Institute, Inc; 1995.

**Citation:** Edward Kuwera, Alexander Christoff, et al. *Measuring Prism in Progressive Addition Spectacle Lenses*. *Archives of Ophthalmology and Optometry*. 2021; 4(1): 08-14.

DOI: <https://doi.org/10.22259/2638-5120.0401002>

**Copyright:** © 2021 Edward Kuwera, Alexander Christoff, et al. This is an open access article distributed under the Creative Commons Attribution License, which permits unrestricted use, distribution, and reproduction in any medium, provided the original work is properly cited.